

Springloaded Pressure Regulator

Model – GRT15S-420

Description

The GRT15S springloaded pressure regulator reduces the supply pressure on the inlet side to a controlled pressure on the outlet side.

Specifications

Inlet pressure	280 or 420 bar
Adjustable	0-420 bar
Connections	1/2" NPT or BSPP
Seat diameter	7 mm
Cv / Kv	Cv 1.0 / Kv 0.85

Fluids

This pressure regulator is suitable for gases and liquids.

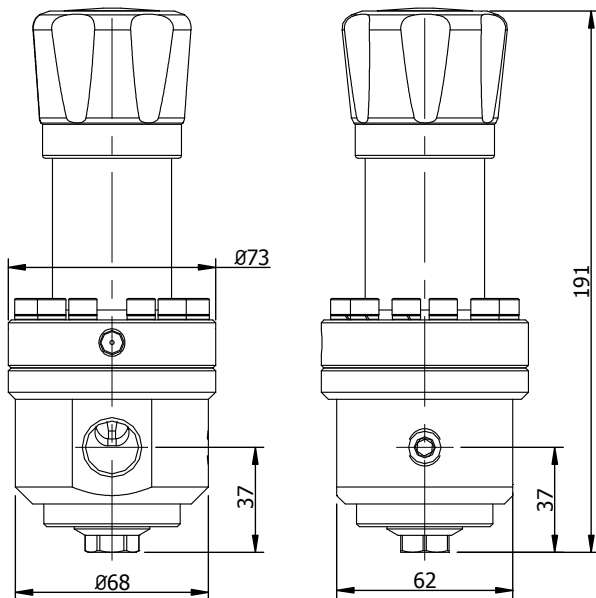
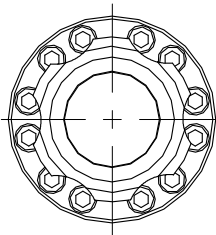

Materials

The regulator is made out of barstock stainless steel material.

Body	ss 316L
Springhousing	ss 316L
Valve	ss 316L
Seat	NBR, FKM or EPDM
Valve spring	ss 316
Setspring	ss 302
O-rings / diaphragm	NBR, FKM or EPDM

Other materials available on request.

All metal parts are marked with a traceable batch number. Material certificates are available on request.

Temperature

The general temperature range of the regulator is -50 / 200 °C, but could be limited due to the used sealing materials.

KEL-F seat	-15 / 60 °C
PEEK seat	-50 / 200 °C
NBR seals	-35 / 130 °C
FKM seals	-20 / 200 °C
EPDM seals	-50 / 120 °C

Springloaded Pressure Regulator

Model – GRT15S-420

Technical details

- all regulators tested before delivery
- leak-tight seat design
- all parts cleaned and degreased
- PED classification SEP
- ATEX classification EXII 3GD

Although this regulator has a leak-tight seat, the regulator should not be used as a shut-off valve.

Spare parts kits are available for the regulator.

Dependency

A character of the regulator is "dependency". The set-pressure will change, when you have a changing inlet pressure.

Adjusting the regulator

The regulator comes standard with a knob. The threadpiece below the knob is designed for frequent adjustment.

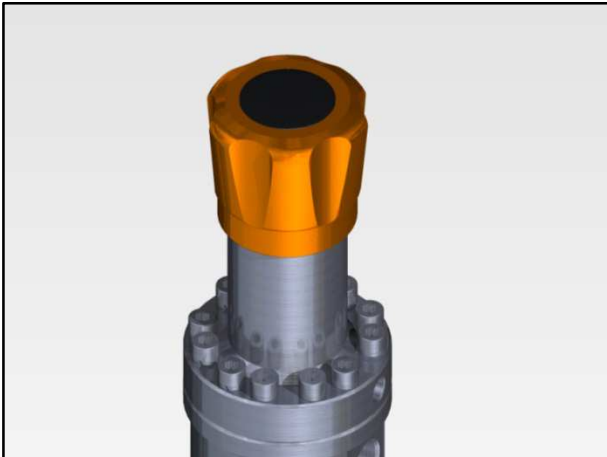

Options

Dutch Regulators supplies the regulators to your needs. When you have the need for special features or options, Dutch Regulators is the right address.

Standard options

- gauge ports
- locking cap

Special options

- other seal materials on request
- other body materials on request
- material according to NACE MR0175

Flow

The regulator has good flow performance over the complete range of inlet and outlet pressures. Always ask Dutch Regulators for advice, if this regulator is the best choice for your application.

Regulators that have a fixed setpoint, can be equipped with a locking cap.



Springloaded Pressure Regulator

Model – GRT15S-420

Section view

The section view of the regulator gives an idea of the internals of the regulator.

- diaphragm sensing up to 20 bar
- piston sensing above 50 bar outletpressure

Gaugeports

The regulator has standard one 1/4" NPT gaugeport to measure the controlled setpressure.

Option G1 and G2 are optional 1/4" NPT gaugeports, see for the position the pictures below.

On request it is possible to have other gaugeports.

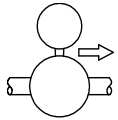

Standard

Outlet gaugeport

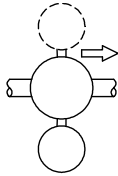

Option G1

Extra
Outlet gaugeport

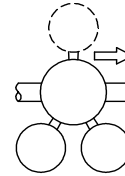

Option G2

Extra
Inlet gaugeport
and
Outlet gaugeport

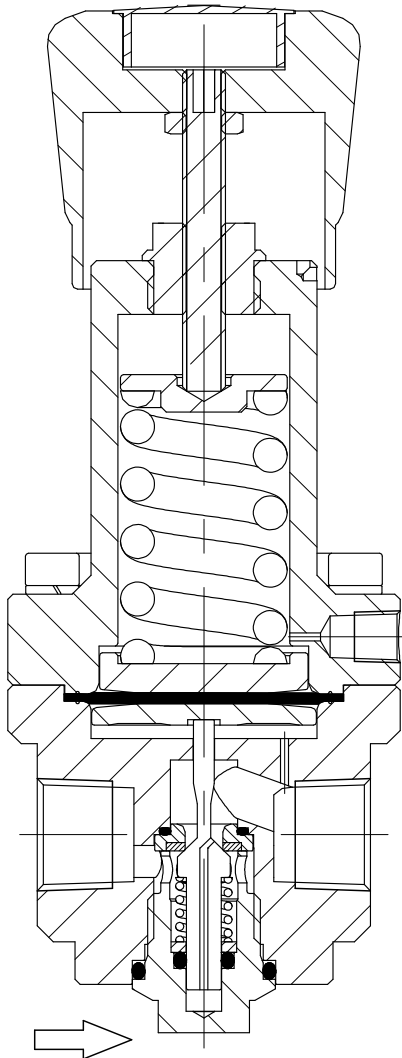

Section view of:
GRT15S-420N20-SSKN

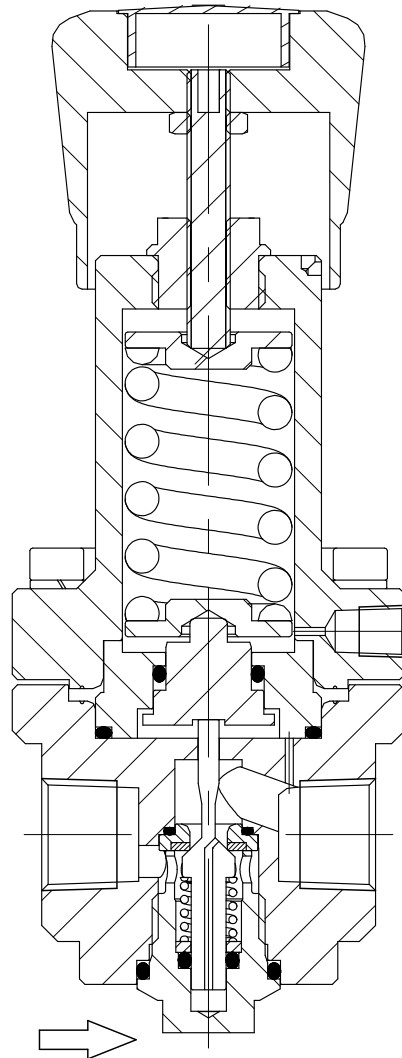

Section view of:
GRT15S-420N100-SSKN

Springloaded Pressure Regulator

Model – GRT15S-420

Mounting holes

The bottom of the regulator has two mounting holes M5 with 8 mm thread and a C-C distance of 35 mm.

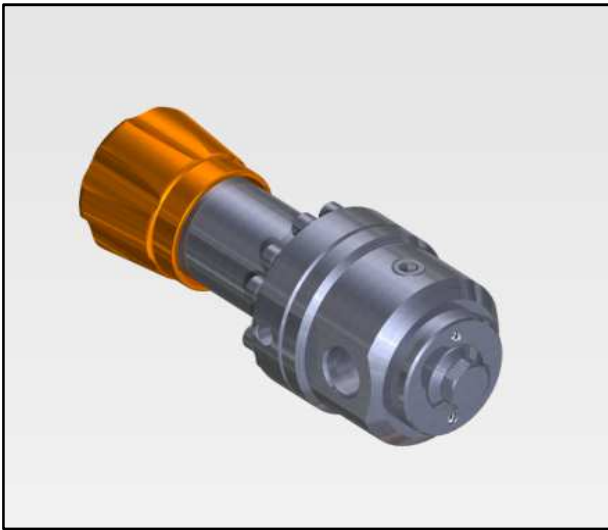

Design pressures

The regulator has a design pressure of 280 or 420 bar, where the design pressure applies for the inlet and outleside.

Depending on temperature or special wishes, the design pressure on the regulator could be different.

Typenumber explanation

Example : GRT15S - 280N20 – SSKN

model	design pressure	connections	adjustable	material	seat	seals	options
GRT15S	280 : 280 bar	N : 1/2" NPT	3 : 0-3 bar	SS SS 316L	K kel-f PCTFE P PEEK	N nitrile NBR V viton FKM E EPDM	G1 one extra gaugeport
	420 : 420 bar	B : 1/2" BSPP	8 : 0-8 bar				G2 two extra gaugeports
			20 : 0-20 bar				
			50 : 0-50 bar				
			100 : 0-100 bar				
			280 : 0-280 bar				
			420 : 0-420 bar				
						xxx codes for special option	

All regulators are marked with a unique ID number, the exact configuration of the regulator is stored in this ID number. Always mention the ID number in case you need spare parts.